

Reliability in Action

Wheeled Loader LG938L



Wheeled Loader L938L

LG 938L Features

- Different size standard buckets
- Side tip bucket
- Multi-function bucket (4-in-1)
- Pallet forks
- Log grapples
- Snow blade
- Attachment bracket and associated attachments

Specifications

Gross Vehicle Mass	10,700 kg
Rated bucket capacity (GP)	1,8m ³
Rated load	3,000kg
Tractive force, maximum	≥ 105 kN
Breakout force, maximum	≥ 96 kN
Gradeability, maximum	30°
Dumping height, maximum	2,950 mm
Dumping reach, maximum	1,050 mm
General dimensions (LxWxH)	7,450 x 2,310 x 3,234 mm

Engine

Model	Weichai Deutz WP6G125E22	Rated Speed	2,200 rpm
Type	In line, direct injection, turbo charged, water cooled	Min.Fuel Consumption Ratio	≥ 207 g/kWh
Maximum Torque	560 Nm	No. of cylinders bore/stroke	6 - ø 105/120 mm
Rated Power	97 Kw		

Transmission System

Make/Model	YD13	Gear Shifts	4 Forward 3 Reverse
Torque Converter Type	Single phase 3 element. Hydraulic	Maximum Speed	36 km/h
Torque Converter Ratio	3.0		
Transmission Type	Fixed shaft electro-hydraulic shift		

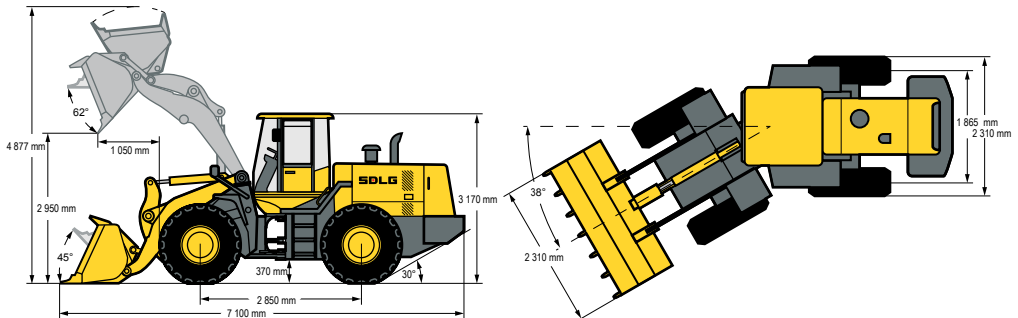

Fully enclosed ROPS/FOPS standard

Front (F) & Rear (R) Axles

Manufacturer	SDLG ZL30F (F&R)	Final Decelerate Type	Planetary gear reduction
Differential Reduction	Helical gear, first stage reduction		

Tyres

Type Specification	17.5 x 25/L3	Rear Tyre Pressure	2.75 - 2.9 Bar
Front Tyre Pressure	3.3 - 3.5 Bar		

Steering System

Type	Articulated load-sensing hydraulic steering
Steering Angle	38° each side

Minimum Turning Radius

Outside Bucket	6,020 mm	Outside Rear Wheel	5,470 mm
-----------------------	----------	---------------------------	----------

Hydraulic System

System Working Pressure	160 Bar	Total Time	≥ 8.6 s
Bucket Rise Time	≥ 5.3 s		

Brake System

Service Brake	Air over hydraulic disk brakes on 4 wheels
Parking Brake	Electrical internal expanding shoe

Fill Capacity

Fuel	140L	Hydraulic Oil	128L
-------------	------	----------------------	------

Not all products are available in all markets. Under our policy of continuous improvement, we reserve the right to change specifications and design without prior notice. The illustrations do not necessarily show the standard version of the machine.



Customer service is first priority

SDLG focuses on delivering outstanding customer service throughout a machine's life cycle. Its Integrated service management system monitors and analyzes the machine's functions to ensure that it is working at optimal capacity, while service alerts notify customers about forthcoming maintenance checks. SDLG's attention to detail is one of the ways it continues to be the industry's No. 1 in terms of customer service satisfaction.

Value-added service

SDLG's aftercare promise guarantees high quality service and offers experts who are on-hand to answer any questions or to solve problems. SDLG's service team uses advanced technology to support its maintenance checks in the field. Moreover, it aims to work with customers to define an efficient business solution.

Global service network

SDLG's worldwide service and spare parts network provides fast, efficient and professional round-the-dock service, anytime, anywhere. SDLG exceeds customers' expectations.



www.sdlg-africa.com



Babcock International Group: Tel +27 (0)11 230 7300 enquiries@babcock.co.za Branches: Botswana +267 390 2869 Bloemfontein +27 (0)51 432 1226 Cape Town +27 (0)21 380 4700 Durban +27 (0)31 700 6009 East London +27 (0)43 001 0090 George +27 (0)44 878 1035 Kathu / Kimberley +27 (0)53 832 3443 Middelburg +27 (0)13 001 1234 Mozambique +258 21 900 120 Nelspruit +27 (0)13 001 1280 Port Elizabeth +27 (0)41 407 5900 Richards Bay +27 (0)35 001 7660 Rustenburg +27 (0)14 592 6150 Steelport +27 (0)13 230 9054 Wolmaransstad +27 (0)18 596 1514 Windhoek +264 61 305 560/3 Zambia Kitwe +260 212 216 200 Lusaka +260 211 127 2926/28 Zimbabwe +27 (0)11 230 7300 Independent Dealer: Polokwane - RGR Services +27 (0)15 297 6711

www.babcock.co.za